

5-2011

Conversion of algal sugars to butanol in a novel automated process

Jill Ivey

University of Arkansas, Fayetteville

Follow this and additional works at: <http://scholarworks.uark.edu/cheguht>

Recommended Citation

Ivey, Jill, "Conversion of algal sugars to butanol in a novel automated process" (2011). *Chemical Engineering Undergraduate Honors Theses*. 30.

<http://scholarworks.uark.edu/cheguht/30>

This Thesis is brought to you for free and open access by the Chemical Engineering at ScholarWorks@UARK. It has been accepted for inclusion in Chemical Engineering Undergraduate Honors Theses by an authorized administrator of ScholarWorks@UARK. For more information, please contact ccmiddle@uark.edu, drowens@uark.edu, scholar@uark.edu.

Conversion of Algal Sugars to Butanol in a Novel Automated Process

An Undergraduate Honors College Thesis

in the

Ralph E. Martin Department of Chemical Engineering
College of Engineering
University of Arkansas
Fayetteville, AR

by

Jill Ivey

April 25, 2011

I completed my honors thesis as part of the EPA's People, Planet, and Prosperity competition. The group, consisting of eight chemical engineering students, was charged with the task of producing butanol from conversion of sugars in algae. The crux of the project was to design, build, and automate a piece of equipment that takes in algae as a feedstock and produces fuel-grade butanol to be used as a biofuel. The process of algae to butanol has been previously studied at the University of Arkansas so we used previous research to determine our basic process of hydrolysis, fermentation, and distillation. Though we had the basic process, we needed to adapt it to a scale we could apply to an automated unit. A group of five of us determined the size of the equipment we wanted to build based on the amount of algae we had available. We used theoretical conversions as well as experimental conversions achieved in previous research to calculate the size the hydrolysis tank, fermentation tank, and distillation columns. This was the basis for our preliminary design.

I took the task of experimenting with the conditions of hydrolysis both in pretreatment and treatment. I designed experiments to test which pretreatment steps were necessary to facilitate hydrolysis, such as drying of the algae and grinding of the algae. The experiments determined both the grinding and drying steps were necessary, and so a grinding step of dried algae was added as a precursor to hydrolysis. I also designed experiments to optimize the conditions of hydrolysis treatment. In these experiments I varied time, acid concentration, amount of water used, and amount of algae used. I performed literature searches to get a baseline for these parameters as well as to determine which variables it was important to

optimize. I analyzed the results of these hydrolysis experiments by determining sugar content by HPLC. I also analyzed the product samples for fermentation experiments by determining butanol concentration using HPLC.

Once the experimentation stage was complete, I took the lead on writing the Phase II section of the report. As a team we adapted the design of the unit, PEACE-1, into a larger, continuous, and more economical system. Once we designed the system we determined cost for each major piece of equipment. We also performed a preliminary economic estimate on our design for PEACE-2. I was responsible for determining material costs for the operation of the continuous unit as well as pricing the hydrolysis CSTR and the hold-up tank. Once we decided on a design for PEACE-2 as a team, I adapted the Phase I PFD to accommodate the changes to the Phase II design. This included replacing first distillation column with pervaporation and incorporating bug recycle for fermentation as well as a hydrolysis holding tank. I then wrote up the proposed design and objectives for Phase II as well as information about partnerships, innovative merit, and benefits to people, planet, and prosperity.

Once PEACE-1 was constructed I performed a costing on the entire unit to be used as part of the economic analysis in Phase I of the report. This costing accounted for each piece of material used in the constructed unit.

Once the report was submitted and the unit constructed, I drafted the design and original language for the poster to be presented at the competition. At the competition, I was responsible for presenting Phase II material of the project as well as being able to answer any question on the project from judges and the public.

APPENDIX

III. TABLE OF CONTENTS

IV. EXECUTIVE SUMMARY 2

 Description and Objective of Research..... 2

 Summary of Findings..... 2

PEACE-1 Design and Construction..... 3

Economics and Sustainability..... 3

Education and Outreach..... 3

 Conclusions..... 4

 Proposed Phase II Objectives and Strategies 4

V. BODY OF REPORT 6

 A. Summary of Phase I Results 6

 1. Background and Problem Definition 6

 2. Purpose, Objectives, Scope..... 7

 3. Data, Findings, Outputs/Outcomes 8

 4. Discussion, Conclusions, Recommendations 12

 B. Proposal for Phase II 14

 1. P3 Phase II Project Description 14

 2. Project Schedule..... 19

 3. Partnerships..... 20

 C. References 21

VI. SUPPORTING LETTERS..... 22

VII. BUDGET AND BUDGET JUSTIFICATION..... 24

VIII. RESUMES 25

IV. EXECUTIVE SUMMARY

NCER Assistance Agreement Project Report Executive Summary

Date of Project Report: March 21, 2009

EPA Agreement Number: SU834701

Project Title: Extraction of Sugars from Algae for Direct Conversion to Butanol

Faculty Advisers: Hestekin, Jamie; Beitle, Robert; Penney, Roy

**Department and Institution: Ralph E. Martin Department of Chemical Engineering,
University of Arkansas at Fayetteville**

Student Team Members: Bevan, Elizabeth; Carter, Ethan; Huslig, Megan; Ivey, Jill;

Nakao, Hiroko; Rakestraw, Kylan; Rostro, Lizbeth; Stout, Jeremy

Project Period: August 15, 2010 through August 14, 2011

Project Amount: \$10,000

Description and Objective of Research

The US imports over 60% of its crude oil on an annual basis. In order to obtain energy independence, different biofuels, feedstocks, and technologies must be explored. The production of butanol from algae is being investigated as a sustainable and potentially lucrative liquid fuel source.

Algae are an exciting new feedstock for biofuel production because of their extremely fast growth rate, high oil and sugar content, and ability to thrive on marginal land water. The bulk of the research on algae biofuels to date has focused largely on the use of the naturally occurring oils in algae to produce biodiesel. However, the majority of the energy contained in algae is stored as carbohydrates, not oils.¹ Although much research has been done on converting algae oils into biodiesel, little has been done on converting the sugars and starches into usable liquid fuels. This has likely inhibited the sustainable commercialization of algae to biofuel technology.

Past research efforts have made significant progress with electric and ethanol-based solutions toward fueling transportation without the direct combustion of fossil fuels. Butanol is a sustainable fuel that has many advantages over other alternatives, including its low vapor pressure, high energy density, and ability to directly replace gasoline.² The higher energy density of butanol relative to ethanol allows for better fuel efficiency in vehicles, giving the consumer better gas mileage. In addition, the physical properties of butanol are such that modern gasoline automobile engines can use butanol directly without major engine modifications.

Phase I investigated a method for producing butanol from algae using a novel automated hydrolysis, fermentation, and separation process. The Phase I research team sought to experimentally optimize individual steps and parameters of the process, design and build an automated unit to produce fuel-grade butanol from algae in a batch process, evaluate the sustainability and large scale economics of the process, and design an outreach program encouraging energy and environmental awareness centered around K-12 students. The team used macroalgae samples obtained through the generosity of the City of New York from Jamaica Bay to test the equipment and viability of the process.

Summary of Findings

Experimental Optimization

Experiments were performed to determine optimal operating parameters for each step of the process in order to reduce energy and material waste and maximize biofuel production.

Optimal pH, temperature, heating time, and water concentration for acid hydrolysis were found by performing trials to determine the conditions that produced the highest sugar concentrations per unit of algae consumed. Fermentation conditions were determined by analyzing the amount of bacteria required, the ideal pH to encourage butanol-producing metabolic pathways, and the necessary time to convert the maximum amount of sugar to butanol. The optimal distillation conditions were determined by altering distillation heating time, reflux ratio and cooling water temperature.

PEACE-1 Design and Construction

The team designed and completed the construction of a demonstration unit. The Portable and Electronic Algae Converting Equipment unit (PEACE-1) takes approximately 1.2 pounds of dry algae and produces 1-2 oz. of fuel-grade butanol. The unit is 3 ft. x 5 ft. by 9 ft. high, can be transported in the bed of a truck, and is operated and controlled by a touch screen located on the front of the unit. PEACE-1 will be transported to Washington D.C. for the National Sustainable Design Expo in April 2011.

Economics and Sustainability

The PEACE-1 unit was constructed for about \$7,000 and requires less than one dollar in operating cost and materials for each batch of operation. Preliminary sustainability calculations were performed for the process to estimate the potential environmental impact of this technology. The combustion of butanol that has been produced from algae is carbon neutral in the sense that the carbon released to the atmosphere during butanol combustion was absorbed from the atmosphere by the feedstock algae. While PEACE-1 uses about \$18 of electricity per pound of butanol, for a continuous system based on this design would use closer to \$0.60 of electricity per pound of butanol. As PEACE-1 was constructed as a proof-of-concept and experimental prototype, energy conservation was not a major concern in its design and fabrication. However, the knowledge obtained in its construction will be paramount in achieving desirable energy efficiency in subsequent algae-to-butanol production systems. Also, the secondary environmental benefits of algae-to-butanol systems are substantial. The algae not only removes nitrogen and phosphorus from water, reducing human pollution of freshwater and saltwater, but the waste solids from the process can be used as nitrogen and phosphorus fertilizer rather than introducing new pollutants into the environment.

Education and Outreach

The efforts of this project have spread throughout the regional academic community and national level. Groups of students from middle schools and high schools in the region, such as McNair Middle School and Russellville High School, have visited the University and seen demonstrations of the process and a remote control car that runs on butanol. Some of the visiting students even competed in a contest to see who could perform a hydrolysis experiment with the best results. Also, over fifteen middle school science teachers from the region attended a workshop at the University of Arkansas where the algae to butanol process and research was showcased. As a result, many visits to and from various schools are currently being planned.

The Phase I team submitted an entry into the Planet Forward contest in February 2011, a contest intended to allow experts and engaged citizens to weigh-in on energy and sustainability.¹⁴ The team received the highest number of internet votes and was invited to be featured on a television special airing in April 2011. Most of the teachers that attended the workshop at the

University of Arkansas have stated that they intend to show the Planet Forward PBS Special in their classrooms.

With the team's success and the project's relatability to the public, many media outlets from the University of Arkansas, Northwest Arkansas region, and localized newspapers throughout the country have exposed the development of the project. The team also plans to submit a manuscript for peer-reviewed publication in *Control Engineering* and received an invite to publish in MIT's new online journal on project-based learning.

Conclusions

Based on Phase I research, butanol production from algae has the potential to be a sustainable alternative fuel technology. Phase I made substantial progress towards successfully demonstrating the production of butanol from algae. A fully automated algae-to-butanol demonstration system was successfully designed, constructed, and operated. The team optimized many experimental parameters in the process. Future development of a continuous process instead of a batch process would improve the economic viability of the process. Based on the energy use analysis performed in Phase I, it is clear that the separation of butanol from the fermenter effluent is a critical step in improving the sustainability of the production process. Therefore more research is required to improve this technology. Phase II proposes to do this by building and optimizing a continuous unit (PEACE-2) that would serve as a potentially marketable unit in both developed and developing countries, serving to clean water, fuel society, and sustain life.

Proposed Phase II Objectives and Strategies

Research with a larger scale unit is necessary to develop more support and awareness from the public, improve on the process technology and efficiency, verify the ability of the process to consume various feedstocks, and optimize the process economics and sustainability. To achieve these goals a slightly larger, continuous version of PEACE-1, called PEACE-2, has been designed to build upon the methods proven successful in Phase I and attempt to make the process more efficient and sustainable. In Phase II, a team of multidisciplinary engineering design students will build, test, and operate PEACE-2 to produce at least 10 gallons of butanol per week. Using the experimentally determined reaction conversions of PEACE-1, the bigger unit would require 130 lbs of dry algae per day. However, a large increase in conversion and efficiency is expected by utilization of continuous operation and further optimization in Phase II. By optimizing continuous fermentation and separation, the goal for PEACE-2 is to operate on 50 lbs of algae per day and have the flexibility to make more fuel. Phase II will be made possible by continuing efforts with the City of New York. Building and operating this unit will allow the Phase II team to experiment with several different feedstocks of algae or other cellulose sources and improve operating variables that affect yield and process efficiency. Phase II will also increase the applicability of the technology to developed areas (PEACE-1 may be shipped and tested on-site near Jamaica Bay) and developing areas (PEACE-1 may be shipped and tested on-site with local farmers eager to utilize the potential benefits of the technology). The Phase II team will continue to develop more partnerships to test either PEACE-1 or PEACE-2. Also, the team will develop more partnerships with potential consumers, students, and the public through educational outreach and an interactive website.

Publications/Presentations

Planet Forward Website:

<http://planetforward.org/idea/invest-in-algae-and-butanol-energy-research/>

MAX-5 News Report Fayetteville, AR:

<http://www.5newsonline.com/news/kfsm-u-of-a-students-turnalgae-into-fuel-20110302,0,4407103.story>

University of Arkansas Newswire:

<http://newswire.uark.edu/Article.aspx?ID=15556>

Morning Sun Newspaper (Pittsburg, KS)

<http://www.morningsun.net/featured/x742403613/PATRICKS-PEOPLE-University-of-Arkansas-students-Earth-Day-project-to-be-featured-on-PBS>

ABS 7 News KGO-TV San Francisco, CA

<http://www.greenrightnow.com/kg0/2011/03/03/university-of-arkansas-researchers-convert-algae-to-butanol-for-auto-use/>

University of Arkansas Newspaper *The Traveler* March 9, 2011

Supplemental Keywords

Butanol, algae, macroalgae, *Clostridium saccharoperbutylacetonicum*, fermentation, ABE fermentation, alternative fuel, sustainability,

Relevant Websites

Planet Forward

<http://planetforward.org/>

University of Arkansas College of Engineering

<http://www.engr.uark.edu/home/4704.php>

V. BODY OF REPORT

A. Summary of Phase I Results

1. Background and Problem Definition

The US currently imports approximately 200 billion gallons of oil per year.³ This dependence on foreign countries threatens national security, the stability of American government and businesses, and increases American susceptibility to fuel price shocks and shortages. Furthermore, the use of oil has significant long-term drawbacks for the environment including contributing to global climate change. There have been many sources of energy proposed to alleviate the foreign oil dependence including wind, solar, nuclear, etc. However, instead of a gasoline replacement, many of these technologies produce electricity, which is currently not compatible with our large automobile fleet.

Crop-based approaches have been proposed for the production of liquid biofuels. The most studied and widely used approach is corn ethanol. However, it has been estimated that in order to replace 50% of the transport fuel with ethanol from corn, it would take over 150% of the cropland in the United States. Thus, in recent years, switchgrass, fast growing trees, etc. have been proposed as potential biomass feedstocks for making ethanol. These feedstocks can grow on more marginal land but the economics are not currently feasible. Biodiesel production from lipids has also been proposed using soybeans, rapeseed, jatropha, and algae. Soybeans and rapeseed are disadvantageous because they require high quality cropland⁴ while jatropha, though it grows on marginal land, is aggressive and invasive.⁵ Algae oils have been explored by many, and much research is going on to optimize oil production.⁶ However, to achieve high levels of oil production, it takes a genetically engineered or selected strain of algae grown under optimum conditions.⁷

It is the opinion of researchers at the University of Arkansas that biofuels should be a sustainable and direct replacement of gasoline, not just an oxygenate. In addition to this, secondary environmental benefits should be exploited whenever possible during the production of biofuels. Therefore, the target of this project is to develop an algae technology that can treat contaminated wastewater, while making butanol, a potential direct replacement for gasoline.

Algae are highly efficient and fast growing organisms that can achieve a photosynthetic efficiency of 5% and increase their mass at the rate of approximately 20 g/m²/day. In contrast, the growth rate of corn grain is only 9.2 mg/m²/day.⁸ At this rate of algae production and with algae possessing a carbohydrate concentration of up to 40%, one acre of algae would yield 1500 gallons of butanol per year, which is nearly 5 times that of corn ethanol.⁹ Combined with the fact that algae can be cultivated on non-arable land with brackish, saline, or waste-water,⁹ their uptake of atmospheric CO₂ and waste-water nutrients (such as nitrogen and phosphorus) makes them more advantageous than other biomass.

Recently, butanol has become an attractive alternative to ethanol due to its low vapor pressure, high energy density, and ability to directly replace gasoline.² Butanol possesses a higher energy density in comparison to ethanol, giving a higher mileage per gallon. In addition, the physical properties of butanol are such that modern gasoline automobile engines can use butanol without any major modifications. Butanol does not require automakers to compromise on performance to meet environmental regulations. Older automobiles also benefit from butanol because it will not corrode rubber seals as ethanol does.

Since natural strains of algae in high nutrient environments produce much more sugar than lipids, this technology has the potential to create a truly sustainable option for the

production of liquid biofuels. In order to demonstrate the feasibility of this technology, a multidisciplinary group of students was formed to achieve the Phase I goals of this project:

1. experimentally develop base-line parameters and complete initial optimization for individual process steps
2. successfully build and operate an automated demonstration unit
3. preliminarily evaluate the sustainability of the process
4. actively encourage energy and environmental awareness centered around K-12 students

2. Purpose, Objectives, Scope

The purpose of Phase I was to investigate a method for producing butanol from algae using a novel automated hydrolysis, fermentation, and separation process. While current processes make butanol from butane refined from fossil fuels, the butanol production process can be replaced by a sustainable alternative—derivation of butanol by fermentation. Fermentation allows for a large degree of flexibility in feedstock selection, because any cellulosic material can be converted to butanol with appropriate adjustments and pretreatment. For the process developed in Phase I, algal matter was chosen as the feedstock for its advantages over other feedstocks. The process was designed to break up the algae cells, convert starches to simple sugars via hydrolysis, ferment the simple sugars to butanol, and extract the butanol from the fermentation broth to create a fuel-grade product. The Phase I research team sought to experimentally develop individual steps and parameters of the process, design and build an automated system to produce fuel-grade butanol from algae in a batch process, evaluate the sustainability and larger scale economics of the process, and encourage the energy and environmental awareness of students. The team used macroalgae samples obtained through the generosity of the City of New York from a site at Jamaica Bay to test the equipment and viability of the process.

Due to the high cost of transporting biomass from the growth site to a processing plant, a large scale facility to produce butanol from biomass is not currently economically viable. However, a small scale unit that could be easily operated in a location where biomass is already abundant may be a viable option for producing biofuels. The unit devised in Phase I is a prototype for such a piece of equipment, *viz.* on-site fuel manufacturing system.

By designing and building an automated prototype unit, Portable and Electronic Algae Converting Equipment (PEACE-1), the team hoped to prove the viability of the process and research the major operating variables of the process, all while having a system that could be operated by anyone with a high school education. With such an automated unit, the power to produce fuel would be put into the hands of the common man and would be available throughout the world with a modicum of operation and safety training.

People, Prosperity, Planet

The conversion of algae into a usable fuel has the potential to yield substantial societal, economic, and environmental impacts. Aside from the obvious economic benefits of producing inexpensive biofuel domestically, this technology would also generate green-collar employment opportunities. Also, since algae does not require high quality farmland to thrive, large scale algae harvesting would not inhibit food production and, therefore, would not contribute to increasing food prices and shortages domestically and abroad. However, on any arable or non-arable land, algae can produce more butanol than could be made from corn or other crops. The feedstock for

this technology can be grown throughout the world. Therefore, there exists the potential to implement algae-to-butanol units all over the United States as well as in developing countries.

Natural algal growth has created unwanted ecological issues in some regions of the world. Overpopulation of some algal blooms can impart negative impacts on other organisms via production of natural toxins, mechanical damage to other organisms, or by other means. Algae-to-butanol technology provides a method to dispose of unwanted algae while producing desirable biofuel. The process has been developed using macroalgae from potential harmful algal growth in New York's Jamaica Bay.

Developing World

The current reliance on petroleum products is not only unsustainable but is also causing irreparable damage to the environment. As developing nations continue to industrialize across the globe, world energy demands and pollution will continue to increase. Therefore, clean, renewable energy production is a matter of increasing importance both in developed as well as developing economies. This technology, with its sustainable feedstock and water treatment capabilities, has the potential to be a viable option for the developing world. PEACE-2 could also serve as a prototype for large scale energy production in the developing countries. The team has arranged to talk to USAID while in Washington, DC for the P3 competition. USAID is interested in developing water and energy technologies for developing countries and upon hearing about this unit, has arranged a seminar.

Educational Tool

In addition to the possible uses for this technology as a sustainable solution to the energy crisis, the project acts as a learning tool for students of all ages. Media outlets including television and written publications were used to educate the public and to stimulate conversation about algae-to-butanol technology and renewable energy in general. Also, the People, Planet, and Prosperity competition was used as a senior capstone class and honors thesis for P3 team members.

3. Data, Findings, Outputs/Outcomes

Experimental Analysis

In the hydrolysis step, simple sugars were produced from starches that were extracted from the dried algae using heat and a 2% sulfuric acid solution. Experimental optimizations were performed to determine the heating time and water concentration that gave an optimal sugar concentration. These concentrations were compared to the theoretical sugar composition of the algae. With the conditions of the laboratory autoclave, 121 °C and 2 bar, the optimum heating time of the five tested times was found to be 50 minutes. The amount of sugars produced by the hydrolysis step were similar in the last three heating times (50, 70, and 90 mins) so 50 minutes was chosen to minimize the amount of heat needed thus reducing energy usage. The amount of dried algae used in the hydrolysis step was also optimized by testing various algae to water ratios and comparing recovered sugar. It was found that 0.06 pounds of algae per pound of water could be used to obtain an optimum sugar concentration needed for fermentation.

In the fermentation system, anaerobic bacteria of the genus *Clostridium* convert simple sugars to acetone, butanol, and ethanol in a 3:6:1 volume ratio, respectively.¹⁰ The metabolic pathways of this process are shown in Figure 1.¹¹ The strain *C. saccharoperbutylacetonicum* was selected for our process because of its high butanol/acetone conversion ratio, tolerance to

oxygen, and ability to utilize algal sugars for their cell growth. The pH, time, and temperature were the three parameters optimized in the fermentation step. It was determined that an ideal pH of 4.8 and a temperature of 35 °C allowed the bacteria to grow and produce butanol. It was also concluded that the maximum amount of butanol produced during the fermentation was produced after 96 hours. The bacteria utilized in the analysis behaved such that the first three days (72hrs) were needed for bacterial growth, which caused the production of butyric and acetic acids. During the last 18 hours the production of butanol occurred. With modifications to the design, a continuous process would eliminate the lag time of bacterial growth and produce more butanol.

In the separation of the butanol from the fermentation broth, two separations steps were necessary to produce fuel grade butanol by batch distillation. A simple two-step distillation system with two decanters was utilized to overcome the heteroazeotrope that butanol forms with water. The optimal distillation conditions were determined by varying distillation heating times, reflux ratio, and cooling water temperature.

Individual optimizations in the previous steps allowed for a greater yield of butanol; however, not all of the available sugars present in the dried algae were converted to fuel grade butanol. The amount of sugars obtained by the hydrolysis step was 0.33 lb sugar/lb algae, while theoretically 0.60 lb sugar/lb algae could be obtained. The amount of butanol that was obtained by the fermentation step was 0.09 lb butanol/lb sugar, while theoretically 0.41 lb butanol/lb sugar could be obtained. The overall amount of butanol obtained was 0.04 lb butanol/lb algae, while theoretically 0.25 lb butanol/lb algae could be optimally obtained. This data is summarized in Figure 2.

The experimental overall conversion of algae to butanol was 12.5% of theoretical conversion. To continue to increase the yield of butanol, as will be addressed in the Phase II proposal, additional steps would be necessary to convert the unit into a continuous process. The team will also analyze which sugars are being converted to butanol and optimize the hydrolysis. Optimization of this step will improve the energy conversion and the economics.

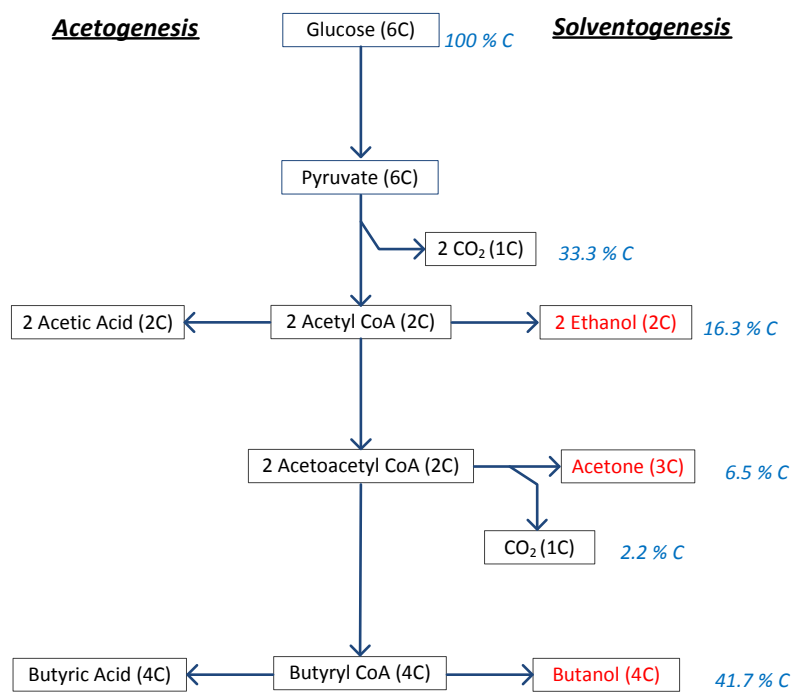

Figure 1. Sugar Fermentation Pathways and mole percentages of carbon end products

PEACE-1 Construction and Operation

The unit was design to be a bench top scale demonstration process. It took about a month to construct the unit and four days to wire all the electrical components. The unit measures 3 ft. x 5 ft. by 9 ft. high and can run on a 5000 W generator. It was designed so that it can

be easily transported in the bed of a truck to an algae rich property. The entire PEACE-1 unit is automated with a programmable logic controller (PLC) manufactured by Direct Logic. The PLC allowed for eight separate control subroutines which, when run in order, complete one full batch of the process, but any of the routines can be run individually as well. The program is written in such a way that the processing can be adjusted to different conditions, feeds and batch sizes.

The operating of this unit is done through a touch screen that is located at the front on the unit, and allows the user to choose what part of the process to run. Also, the interface allows for the user to adjust the parameters to their feedstock and desired operating conditions. The feed algae valve is the only part of the process that is not automated. The other manual labor required is the refilling of all solutions and nitrogen, adjustment of pump speeds and nitrogen pressure.

The process was designed to produce approximately 1-2 ounces of butanol from a charge of 1.2 lbs of dried *ulva* macroalgae in four days. Approximately 25 to 30 kW-hr of energy and 2 gallons of water are required for each butanol production run.

The processing of the algae begins with algal biomass that is dried upon harvesting for transportation and storage. The feed materials are ground into small particles to facilitate the subsequent hydrolysis reaction. A 6 in. diameter x 18 in. tall 304 stainless steel reactor containing a magnetically driven agitator is first charged with 2 lbs of the ground algae, followed by the addition of 2 gallons of 2% sulfuric acid solution. The reactor is then heated to maintain a temperature of 121 °C during the 50 minute hydrolysis process. Following the reaction, the reactor is flashed and subsequently cooled by cooling water down to 37 °C. The pH is then raised to 4.8, an optimum level for fermentation, by adding 2 M sodium hydroxide. Afterwards, the hydrolysate is transferred to the fermentation vessel through a screen at the bottom of the reactor by gravity and by pressurizing the system with nitrogen supplied at 4 bar.

An 8 in. diameter x 12 in. tall 304 stainless steel reactor is used for the fermentation process. After the vessel is charged with filtered algal hydrolysate, the broth is inoculated with 100 ml of the culture of *C. saccharoperbutylacetonicum*, which is prepared in a broth of trypton, yeast extract, and glucose monohydrate. The fermentation is run at a temperature of approximately 35 °C with constant agitation. After 96 hours, the reaction is terminated by

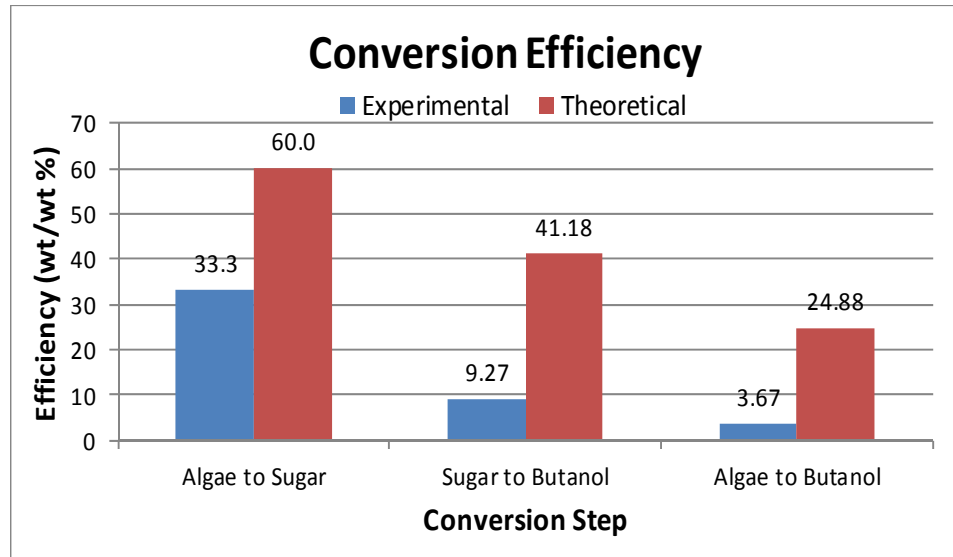

Figure 2. Conversion Efficiency of Algae to Fuel Grade

heating the fermentation vessel to prohibit further bacterial growth and is followed by the distillation process, in which the vessel also serves as a reboiler.

After initiating the distillation cycle by boiling the fermentation broth, the first column is run at total reflux for 30 minutes to eliminate any possible column holdup of the butanol-rich phase. The distillate is then allowed to collect in a decanter, in which the interface level of the two-phase liquid is measured by a float. The heavier phase, consisting of approximately 93 mol % of water, is refluxed until the interface level reaches the bottom of the decanter. The 50 mol % butanol phase is then sent to the next column. This second column also produces a two-phase solution in the distillate, of which the lighter phase that contains only a small amount of butanol is refluxed back to the second column at the reboiler. The second distillation is ended when the reboiler temperature reaches a point near the boiling point of butanol. Fuel grade butanol is retrieved from the reboiler.

Economics and Sustainability

The PEACE-1 unit was constructed for about \$7,000, and requires less than one dollar in operating cost and materials for each batch of operation. Preliminary sustainability calculations were performed for the process to estimate the potential environmental impact of this technology. The combustion of butanol that has been produced from algae is carbon neutral in the sense that the carbon released to the atmosphere during butanol combustion was absorbed from the atmosphere by the feedstock algae. As PEACE-1 was constructed as a proof-of-concept and experimental prototype, energy conservation was not a major concern in its design and fabrication. While PEACE-1 uses about 600 kWh of electricity per pound of butanol, estimations performed for a continuous system would use closer to 20 kWh per pound of butanol. The preliminary overall conversion of the system was 0.037 lb of butanol per lb of algae, but the theoretical yield is as much as 0.240 lb butanol per lb of algae, nearly eight times higher. The knowledge obtained in the construction of PEACE-1 will be paramount in achieving desirable energy efficiency in subsequent algae-to-butanol production systems. Also, the secondary environmental benefits of algae-to-butanol systems are substantial. The algae not only removes nitrogen and phosphorus from water, reducing human pollution of freshwater and saltwater, but the waste solids from the process can be used as nitrogen and phosphorus fertilizer rather than introducing new pollutants into the environment.

Education and Outreach

The efforts of this project have spread throughout the regional academic community and nationwide. Demonstrations were given both at the University of Arkansas and on-site at many schools in Northwest Arkansas. Students that visited the campus from schools such as McNair Middle School and Russellville High School learned about the concept and sustainability of the process and also got to play with a remote control car that runs on butanol. Some of the visiting students even competed in a contest to perform algae hydrolysis and to produce the highest concentration of sugar. Two of the students that participated in this exercise have since signed up to study chemical engineering at the University.

Middle school science teachers from every school in the region attended a workshop at the University of Arkansas where the algae to butanol process and research was showcased. Feedback from the teachers indicated the project was an effective way to introduce young students to energy and get them excited about science. As a result, many visits to and from

various schools are being planned. Most of the teachers also said they intend to show the Planet Forward PBS Special to their classroom.

The Phase I team submitted an entry into the Planet Forward contest in February 2011, a contest intended to allow experts and engaged citizens to weigh-in on energy and sustainability.¹⁴ The Planet Forward competition highlights different groups across the country that are doing something unique to propel the United States and the world towards a more sustainable future. The Phase I team's algae to butanol unit was one of the seven finalists, receiving the most online votes, and will be featured on a special airing in April 2011. While in Washington, D.C. to film the PBS Special, the team had the privilege of meeting with Rep. Steve Womack to share the concept of the project with his constituents. Subsequently, the team has been invited to talk to both Arkansas senators while back in April.

With the success of the team and the ability of the public to relate to the project, media from the University of Arkansas, Northwest Arkansas, and localized newspapers throughout the country have documented and exhibited the development of the project. The team also made plans to submit a manuscript for peer-reviewed publication on the control system as well as writing a manuscript on the project based learning process of building this unit.

4. Discussion, Conclusions, Recommendations

An automated unit was built that was able to take in algae as a feedstock and produce a biofuel, butanol. The automation of the unit allowed for very minimal manual operation and maintenance. The operator merely needs to input algae, press the red button, and, in four days, collect butanol. Not only did the automation allow for the unit to run successfully and smoothly, it also minimized contamination in each piece of equipment, which was necessary to produce the maximum amount of butanol. By automating the system, it gave the ability to produce biofuel to the common man. Preliminary optimization of the hydrolysis, fermentation, and distillation allowed for the best possible prototype system. Optimal heating time, and water concentration achieved 0.3 lb of sugar per pound of algae, but the highest theoretical conversion is 0.6 lb of sugar per pound of algae. If the actual process yield increased to 0.5 lb of sugar per pound of algae, the amount of algae required to make the same amount of butanol would decrease by 40%. Fermentation conditions were determined by analyzing the amount of bacteria needed and the appropriate pH to produce butanol, while still allowing bacterial growth, and the time necessary for the maximum conversion of sugar to butanol. Because the batch process of Phase I had a major lag-time at the beginning of fermentation to grow bacteria, the overall sugar to butanol conversion was only 0.092 lb of butanol per pound of sugar, when the maximum theoretical conversion is 0.4 lb of butanol per pound of sugar. If the actual conversion could be increased to 0.2 lb of butanol per pound of sugar the amount of butanol produced would more than double. The optimal distillation conditions were determined by altering distillation heating time, reflux ratio and cooling water temperature. Distillation used nearly 40% of the total amount of energy in the unit. Therefore, to further optimize the unit in Phase II, a different and less energy intensive form of separation should be explored, such as pervaporation. To further increase the yield of butanol additional research and development would be necessary to convert the unit into a continuous, and therefore more efficient and economical, process. If the energy of production could be reduced by 17%, at a butanol price of \$3.00 per gallon the process would recoup operating costs. The current process also recoups operating costs if the price of butanol fuel rises to \$3.50 per gallon. While the technology to convert algae into a biofuel is not original, this project is the first known one of its kind to develop a complete, automated process to extract and

ferment the sugars from algae into fuel-grade butanol. Further, PEACE-2 will use state of the art fermentation and separation technology to improve the overall economics.

This project branches out to many areas, including, chemistry, microbiology, engineering, biochemistry, and electrical engineering. As a result of such a multidisciplinary team, the group has gained valuable experience in all of these areas that the members would not normally have obtained. The entire experience served to strengthen each individual team member's engineering skills, which will be invaluable to them as they prepare to enter the workforce or further their education. These skills include applying engineering design concepts as well as laboratory experimentation and data analysis. Finally, the group environment fostered the development of interpersonal communication skills and teamwork.

Movement towards Sustainability

The prototype unit that was built in Phase I helped show that the process of converting algae to butanol is possible and there are several optimization possibilities. The need to build a continuous unit to produce a significantly larger quantity of butanol is necessary. With such a unit, proposed in Phase II, it would be possible to make an impact in reducing the amount of fossil fuels used in America. Algae are a sustainable alternative to other feedstocks with many environmental benefits. Algae are carbon neutral--it takes in as much carbon as it produces from being used as fuel. This technology is directly applicable to the developed world, especially the United States. According to the 2010 agricultural census, there were over 2.2 million farms in the United States with an average farm size of 418 acres.¹² Thus, if a farmer chose to convert approximately 10% of the non-arable land to growing algae, a significant portion of the fuel used for agricultural practices could be made on site. If larger full-scale plants were built to convert algae to butanol, more fuel could be produced to significantly decrease the amount of gasoline consumed in the United States.¹³ Further, algae grow on non-arable land and thus this process can also be used to clean-up wastewater on land that is not suitable for crops. This technology is also directly applicable to developing countries. If the process is sold as small scale units, the technology can be transported anywhere, provide people with a much needed clean water supply and fuel, use a feedstock that is readily available, all while being able to operate without a substantial technological background. Using this process of converting algae to butanol to make usable fuels allows developed and developing countries to move towards sustainability.

Partnerships

Connections and relationships with various groups and organizations have fostered the implementation of the unit, along with the ability to inform the general public about the need of a sustainable fuel and the ability of algae to fulfill that role. One such partnership with the City of New York has allowed for a continuous supply of macroalgae to be obtained and tested in the unit. During Phase II, a continuous, automated unit would be shipped to Jamaica Bay in New York City where on-site tests would determine how the unit works outside of the laboratory. Partnering with Rockaway Wastewater treatment plant in New York City, the building of the unit could be paired with the growth of algae specifically intended to clean-up water. Algae, as mentioned above, have the ability to clean up water where nitrogen and phosphorus may be present and actually grow faster when these elements are present. A raceway is already in place that grows algae using the discharge water from the treatment plant.

Along with the implementation of the unit at different sites where algae is present, the unit has been a great educational tool. Here at the University of Arkansas, the unit has been used

to expose middle school students, high school students, and the college community to the importance of environmental awareness and the use of energy. The support of many University of Arkansas media outlets, such as the *Arkansas Traveler*, has helped the students to understand alternative energy options and the potential impact they could have on our economy and environment. The local media have been helpful in informing the Northwest Arkansas community of the project and the need for a sustainable fuel. The project was featured on several different broadcasts, including KNWA and Max-5 TV coverage, which introduced the project to the northwest and central regions of the state (the main population centers) as well as online communities. In Northwest Arkansas, the idea of producing a sustainable fuel has been very well received. The Phase I team has had the opportunity to share the process of building the unit with other areas of the country as well, mainly with the help of media coverage and online social networks.

The team conducting algae to butanol research was a finalist on PBS's Planet Forward competition. This exposure has allowed the P3 group to network with people across the country, to promote the idea of an environmental fuel, and to continue educating citizens on the importance of moving towards sustainability. While filming for the competition, the team was approached by several people who were interested in purchasing a unit to put on their farmland to use the algae that they already have to produce usable fuel-grade butanol. Therefore, as stated in Phase II, one of the major goals is to test the unit on farmlands. Outreaching to farmers, especially those that may grow corn for ethanol, would allow the farmers to produce a better fuel at a greater yield. If algae-to-butanol were to replace corn-to-ethanol, farmland used for producing feedstocks for fuel would be reduced by 80%. This would allow for 80% more land to be available to produce food that could help combat the growing need to help feed the developing nations. Further, algae can grow on non-arable land and thus can be used to clean-up wastewater with all of the nutrients coming from the wastewater. Overall, the project has the capability of not only changing the ways that Americans use fuels and clean up wastewater, but effects from these two areas would help benefit other nations as well, especially developing countries. The team is giving a presentation to USAID in April to explore the potential of this unit being used in developing countries.

B. Proposal for Phase II

1. P3 Phase II Project Description

Relationship to Sustainability and Sustainability Benefits

The proposal for Phase II of this project focuses on further developing the technology to convert algae to fuel-grade butanol in a usable 10 gallon per week system. The sustainability calculations in Phase I indicated that the algae to butanol process has the potential to be economically and environmentally feasible. Implementing a process utilizing the conversion of algae to butanol would cause positive impacts to ripple throughout all aspects of society. According to the Energy Information Administration, the United States currently imports 5 billion barrels of oil per year.³ The production of fuel from algae could reduce society's dependence on imported fossil fuels, which would in turn strengthen national security and secure the United States economy against fuel price shocks and shortages. By producing fuel from feedstocks grown locally, the economic benefits would resonate to domestic as opposed to foreign economies.

Using a feedstock that is naturally abundant and not a source of food benefits society by securing the current food supply for human consumption. The current trend is to produce

biofuels from crop-based feedstocks, primarily corn and soybeans. Not only does using these sources make the United States susceptible to food shortages and price increases, but also making fuel from these sources requires extensive resources such as water, fertilizer, land, and energy (for growth, harvest, and transportation). In contrast, algae feedstocks only require the energy involved in collection, transportation, and transformation to butanol. Algae are also an environmental asset in their ability to clean waterways by removing excess nitrogen and phosphorus that threaten the aquatic ecosystem. In addition, the waste solids from the algae to butanol process can be used as nitrogen and phosphorus fertilizer, completing a reusable cycle. By partnering the production of algae for fuel with areas that have the necessity to clean water ways, the combined advantages add to the economic viability of the process. For instance, the algae grown at algal raceways for water treatment can be harvested and used as the biomass for the system that has been developed. The team has partnered with the Department of Environmental Protection in NYC with hopes of implementing a process that simultaneously cleans the waste-water and produces butanol.

Using fuel from algae will help to abate the global climate change that the use of fossil fuels exacerbates. Because of the large quantities of fossil fuels used today, sequestered carbon continues to be rapidly reintroduced into the environment, causing increasing acidity in oceans, destruction of habitats, air pollution, as well as irreversible global climate change. It is increasingly clear that reducing consumption of non-renewable resources will be one of many critical steps on the path towards achieving sustainable life. Using algae as a feedstock for fuel production will reintroduce less sequestered carbon into the carbon cycle due to the fact that the butanol combustion process is carbon neutral in the sense that it takes in the same amount of CO₂ that is released to the atmosphere as a result of the fermentation reaction and butanol combustion. Small scale, continuous, automated butanol product systems could be used by farms, businesses, municipalities, and private individuals to produce their own fuel supply. Using fuel produced from their own readily available feedstock would allow users to decrease costs, increase profit margins, and increase overall quality of life.

In order for industrial production of butanol to be profitable in the long term, further research is required in determining optimal conditions to make butanol an economically competitive alternative to gasoline. The most significant short-term cost for the implementation of fermentation-produced butanol is further research in the areas of fermentation operating conditions and butanol separation. Phase II of this project, which would allow for the necessary optimization research as well as actual implementation of prototype equipment, is an important intermediate step in the progression towards butanol as a sustainable fuel option.

Challenge Definition and Relationship to Phase I

In Phase I, it was shown that algae could be successfully converted to butanol via the bacteria *Clostridium saccharoperbutylacetonicum*. Research on a larger scale is necessary to the development of a full-scale design of a continuous, economically viable butanol fermentation process from algae biomass. To achieve this goal, a pilot-scale model has been designed that incorporates and builds upon the methods proven successful in Phase I.

A new team of students, working with ecologists and microbiologists, will build and operate the continuous unit with guidance from faculty advisers. The first area of focus will be to obtain a greater yield, via the continuous process, rather than the batch process as seen in Phase I. This will require an optimization between the residence time in the fermenter and the

conversion of sugars and starches to butanol. Using the data collected from Phase II, the students will build and operate a continuous unit.

The team will also send PEACE-1 to sites, such as Jamaica Bay, NY to test the effectiveness of the conversion of algae to butanol in the field.

The main goals for developing and optimizing this technology in Phase II, to be performed by a group of multidisciplinary students are as follows:

1. experimentally design a continuous process that will achieve at least 10% overall process conversion
2. successfully design and build a continuous macroalgae unit
3. implement and operate PEACE-1 on-site at a polluted water way
4. collect and analyze data from on-site operation to determine efficiency of PEACE-1
5. evaluate and optimize the economics and sustainability of the process
6. experimentally determine the possibility of using multiple feedstocks in the process
7. continue and expand the current outreach program encouraging K-12 students to be environmentally aware
8. continue to pursue partnerships and find sites for unit operation

Innovation and Technical Merit

The idea of recycling waste to produce a useful product is not new, especially with sustainability being on the forefront of national attention; nor is the idea of using agricultural products to make fuel. However, using algae, considered by most to be unusable, as a feedstock to produce butanol is unique. Coupling fuel production with environmental cleanup is an innovative approach to simultaneously tackling two major problems plaguing society. The merit behind this process resides in the superior nature of butanol to act as a biofuel as well as the societal and environmental benefits of algae as a feedstock. The process proposed for the unit to be built in Phase II can be seen in Figure 3.

Phase II will be implemented at the University of Arkansas Chemical Engineering Department during the fall 2011 and spring 2012 semesters. An automated farm-scale unit will be designed and constructed to convert 130 lbs of dried algae to approximately 10 gallons of butanol each week. The student team will gather experimental data, build the unit, and collect data on the operation of the automated continuous process. The team will also implement the operation of PEACE-1 on the polluted water ways of Jamaica Bay as well as exploring uses on partnered algae farms. The entire cost of the project including construction and operation of the macroalgae unit and implementation of PEACE-1 on-site will be under \$75,000. A breakdown of expenses can be found in the attached budget justification sheet.

PEACE-2 will operate on a charge of 130 lbs of algae supplied to the inlet every week. The algae feed will be ground and then gravity fed to a hydrolysis reactor. After the algae are hydrolyzed to release the sugars, base is added to adjust the pH to the optimal fermentation conditions. The hydrolysate will be pumped into solids separation apparatus to remove solids before fermentation. The solids waste removed from the process can be used as fertilizer. The liquid hydrolysate will feed to the fermenter via a holding tank. The sugars in the hydrolysate will be converted to butanol by the bacteria *C. saccharoperbutylacetonicum*, which will be separated by a membrane and recycled back into the fermentation vessel. The liquid stream exiting the membrane will be supplied to a pervaporation unit. The butanol heavy stream coming out of the pervaporator will be fed to the distillation column, which will produce butanol of 99% purity.

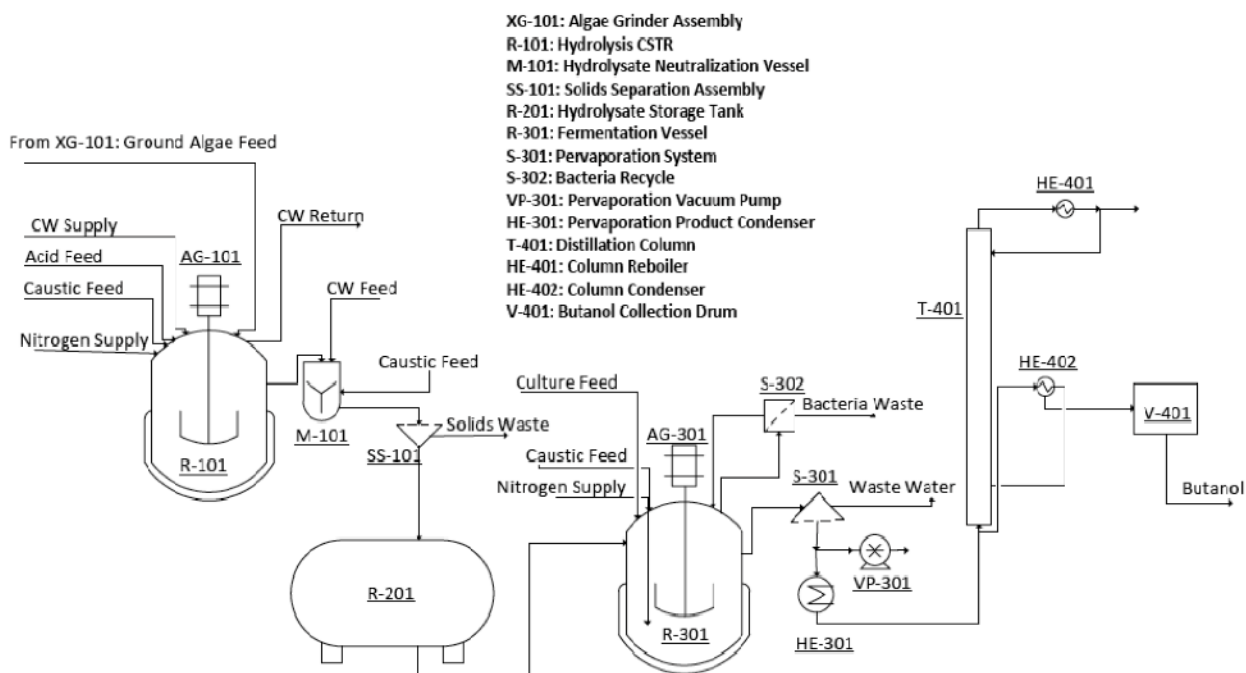

Figure 3. Pilot Scale Process Flow Diagram

Many innovative techniques must be applied to the Phase II process to raise the efficiency to make the process commercially viable. Phase II will utilize a continuous, fully automated process for the treatment of dried algae feedstock, as opposed to the batch process of Phase I. The fermentation in Phase II will be achieved in a custom built unit, utilizing pH and temperature control. Phase II will implement the use of a hollow fiber membrane to extract the fermentation broth for separation while recycling the bacteria back to the fermenter. A portion of the reactor effluent could be purified by pervaporation, which will effectively remove excess butanol that would inhibit the fermentation reaction. This will allow for continual production of butanol by the bacteria in the fermentation step, making for a much more efficient process. As the butanol is removed from the fermentation process it will be sent through a distillation process, using a single column and one decanter to remove the remaining water and achieve the desired purity of butanol. The final product will be a nearly pure organic mixture of butanol, ethanol and acetone (~99.7%). This product will be fuel-grade and can be used directly in current gasoline tanks. The ethanol and the acetone made in Phase II will be separated off the distillation column as mixed solvents. This will be used in a burners to provide heat sources for the hydrolysis and distillation thus further lowering energy requirements for the unit.

Measurable Results, Evaluation Method, and Demonstration Strategy

The primary goal of Phase II is to design and build a farm-scale unit for the production of butanol from algal feedstocks and evaluate the economic feasibility of this unit. To be economically viable as an alternative to fossil fuels, the product must be based on a process with relatively low energy use. In Phase II, further research must be done into the optimization of the separation of butanol from an economic standpoint. Pervaporation technologies will be

optimized to minimize energy expenditures and maximize separation. The students will determine the most favorable operating temperature, flow rate, and vacuum pressure for the pervaporation system using a factorial experimental design to determine the optimum membrane flux. Investigations and experimentation will also be done with regards to capturing the energy used in the separation to be recycled back into the process.

Experimentation is also needed to optimize the fermentation process. Implementing a continuous fermentation system allows the possibility for a higher yield of butanol by increasing the concentration of algae in the hydrolysate. However, an increase in butanol present in the fermentation tank can inhibit the bacterial production of butanol. In Phase II, experiments will be performed to investigate processes that can remove butanol from the fermentation step to prevent inhibition of the bacteria from the increased butanol. Experimentation in Phase II will determine the optimal yield of butanol that can be produced by the bacteria in fermentation, and the concentration of algae in the hydrolysis operation that will lend that optimal butanol yield.

Phase II will consist of the construction of a unit that can be placed in an area of algal growth. Once this unit is built and is operating, a life-cycle assessment will be performed on the unit to establish the economic viability of the product.

Phase II will also entail shipping PEACE-1 to Jamaica Bay in New York City for an on-site trial operation. The unit will come equipped with a user manual so operators on-site will have the ability to self-operate the unit. An operator will need to feed the dry algae at the beginning of each run and refill solution bottles and nitrogen. Pump speeds and nitrogen pressure can also be controlled manually by the operator. The operator in Jamaica Bay will keep a log of operational problems and general feedback. This information will be used to calculate yield of butanol when analyzing effectiveness of the process. Once this information has been gathered from the trial, the team will make necessary adjustments on the unit as well as incorporate possible improvements into the design of PEACE-2. After the trial in Jamaica Bay, the unit will be sent to another location, which will be determined through further correspondence with potential partners in Phase II.

In Phase I of this project several partnerships were explored. A strong partnership has been developed with the Department of Environmental Protection in New York City. Jamaica Bay in New York City has promised to continue the partnership throughout Phase II by providing a consistent supply of algal feedstock for experimentation as well as a location for the product implementation. Phase II will continue to build on these relationships established in Phase I as well as establish new relationships with areas where algae is prevalent.

Integration of P3 Concepts as an Educational Tool

Phase I was an effective educational tool because it required the design team to utilize a wide variety of skills including, but not limited to, engineering, economical, and biochemical understanding of the process. In addition, the students performed a sustainability analysis for the production of butanol from algae.

Phase II of this project will continue to enrich the educational experience of students involved in the project. For this phase, the design team will scale up the batch system evaluated in Phase I into an operational continuous unit. The students will collect data and optimize the process to maximize its efficiency. The student team will perform this work as a requirement for their senior capstone design course. The detailed design, construction, and operation of this unit will give the students invaluable experience in applying their academic knowledge to a real-world situation. The continuous plant design and the research to be performed in Phase II has

great potential to extend beyond the capstone design course requirements. This project would be well-suited for individual students, both undergraduate and graduate, to continue research. Graduate students are already researching ways to optimize the process of the production of butanol from algae using the built batch unit.

Phase II addresses the needs and interests of areas that have an overabundance of algae. It allows these places to be able to turn their algae into a usable biofuel, butanol, using the easy-to-run, batch system.

If Phase II is successful, a full-scale process will be designed that could be built to output a large amount of butanol. This new design would be a full-scale plant, allowing for the production of a significant amount of butanol, that would actually be able to compete with gasoline, and its rising prices. Building a full-scale plant, to be run on a continuous basis would mimic the design of the continuous, but small unit, designed in Phase II. Phase II is an essential stepping stone from moving from Phase I to making this idea an actual possibility. Designing the Phase II unit, as well as the full-scale design, would allow students a rich educational experience for the Phase II team and to increase the awareness of environmental sustainability to University of Arkansas students and those interested in using such a unit.

Interdisciplinary Teamwork

Phase II will involve work across multiple disciplines and will utilize a team of various strengths. The Phase II team will be comprised of students with backgrounds in chemical engineering, electrical engineering, mechanical engineering, business, marketing, economics, communications, food science, and microbiology. The team will also work with experts in biology and ecology to implement an environmentally sound system.

2. Project Schedule

Task 1: Review Phase I Work (Months 1-2)

Phase II students will review the work completed by the Phase I team and make any changes to the design they deem necessary.

Task 2: Grow Clostridium Culture (Months 1-6)

To build up a stock of bacteria culture, begin growth of *C. saccharoperbutylacetonicum*.

Task 3: On-Site Testing of PEACE-1 (Months 1-6)

The team will ship PEACE-1 to Jamaica Bay for on location implementation. Weekly reports will be received from on-site operators regarding the operations of the unit.

Task 4: Purchase Pilot Plant Components (Months 2-4)

Students will purchase all of the components for the pilot plant using the process flow diagram and the itemized budget proposed by the Phase I team.

Task 5: Construction of Pilot Plant Unit (Months 3-6)

Students will construct a pilot plant at the Engineering Research Center (ERC) with faculty guidance.

Task 6: Start-up (Months 6-7)

Students will test all processes in the plant for proper functionality.

Task 7: Plan for algae collection (Months 1-3 and 8-9)

Students will work with sites in Jamaica Bay, Chesapeake Bay, and on the Arkansas and Mississippi Rivers to obtain different samples of algae to be used in the unit.

Task 8: Test Full Scale (Months 7-9)

Students will work for four weeks to test the pilot plant on a continuous daily basis. One week

of testing will be done with regular media, and then three weeks of testing will be done with algae.

Task 9: Economic Analysis (Months 6-8)

The team will continue to evaluate the economical viability utilizing the information from the pilot plant.

Task 10: Report Results (Months 4-8)

The experimental results of Phase II will be documented. These findings as well as a university scale model of a butanol production facility will be presented to the University of Arkansas Sustainability Council. If applicable, the students will work towards publication of their results.

	Task Name	Aug 2011	Sep 2011	Oct 2011	Nov 2011	Dec 2011	Jan 2012	Feb 2012	Mar 2012	Apr 2012		
1	Review	█										
2	Culture Growing	█										
3	PEACE-1 Testing	█										
4	Purchase		█									
5	Construction			█								
6	Startup							█				
7	Collection	█							█			
8	PEACE-2 Testing								█			
9	Economics						█					
10	Report				█							

Figure 4. Project Schedule

3. Partnerships

Phase II of this project will continue the partnership that has been developed with the Department of Environmental Protection in New York City. The team at the University of Arkansas will continue to receive *ulva* algae from the Harmful Algal Blooms in Jamaica Bay to continue experiments in optimizing butanol production from algae. Jamaica Bay will supply the University with a sufficient supply of algae to optimize the process proposed for Phase II. In addition, the partnership with the government of New York City will provide a desirable location for the implementation of PEACE-1. The abundance of algal blooms make Jamaica Bay an ideal location for installing the product on-site for on-site testing and optimization that will be done in Phase II. The Department of Environmental Protection in New York City has written a letter of support outlining their intention to both continue to supply algae and allow for on-site implementation and testing once the product is operating. This partnership is the first of many that will be formed with areas of heavy algal blooms and may be also tested with algal raceways at the Rockaway Wastewater treatment plant. Further partnerships will be made to allow for implementation of the product in other areas with sufficient algal feedstock currently growing.

The team in Phase II will also be working closely with the Ralph E. Martin Department of Chemical Engineering, the Microelectronics and Photonics Program, and the Molecular Biology Program to continue researching butanol from algae. The chemical engineering department has given their full support to using Phase II as credit for the honors section of the senior capstone design course (CHEG 4443). In Phase I, students also received credit in Microelectronics and Photonics as well as credit for Honors Thesis and this will be explored for Phase II as well. All involved departments and programs have viewed this project as a worthwhile educational tool.

C. References

1. Burlew, J. (1976). *Algal Culture: From laboratory to pilot plant*. Washington, D.C.: Carnegie Institution of Washington Publication.
2. Keasling, J. & Chou H. (2008). *Metabolic engineering delivers next-generation biofuels*. 298-299. Retrieved from <http://www.nature.com/nbt/journal/v26/n3/abs/nbt0308-298.html>
3. “International Energy Statistics”, www.eia.doe.gov, search: title
4. Heimlich, R. & Searchinger, T. (2008) *Estimating Greenhouse Gas Emissions from Soy-based US Biodiesel when Factoring in Emissions from Land Use Change*. 35-45. Retrieved from <http://www.farmfoundation.org>
5. Ravindranath, N., Manuvie, R., Fargione, J., Canadell, J., Berndes, G., Woods, J., Watson, H., & Sathaye, J. (2008) *Greenhouse Gas Implications of Land Use and Land Conversion to Biofuel Crops*. 111-125. Retrieved from <https://files.pbworks.com>
6. Danielo, O. (2005). *Biofutur: An algae-based fuel*. Retrieved from <http://www.climatebabes.com>
7. Schenk, P. & Thomas-Hall S. (2008). *Second Generation Biofuels: High-Efficiency Microalgae for Biodiesel Production*. 20-43. Retrieved from <http://www.springerlink.com>
8. Brooking, I. (1993). *Effect of temperature on kernel growth rate of maize grown in a temperate maritime environment*. 135-136. Retrieved from <http://www.sciencedirect.com>
9. IEA Bioenergy. (2009). *Algae-The Future for Bioenergy?* Retrieved from <http://www.ieabioenergy.com/DocSet.aspx?id=6436>
10. Pizarro, C., Mulbry, W., Blersch, D., & Kangas, P. (2006). *Ecol. Eng.* 26, 321-327.
11. Neori, A., Chopin, T., Troell, M., Buschmann, A. H., Kraemer, G. P., Halling, C., Shpiguel, M., & Yarich, C. (2004) *Aquaculture*. 231, 361-391.
12. USDA Economics, Statistics and Market Information System. (2010). *Farms, Land in Farms, and Livestock Operations*. Retrieved from <http://usda.mannlib.cornell.edu>
13. Energy Information Administration. (2006). *Table F9a: Total Petroleum Consumption Estimates by Sector*. Retrieved from <http://www.eia.doe.gov>
14. Center for Innovative Media. (2011). *About Us: PlanetForward on TV*. Retrieved from <http://planetforward.org/about/about-us/>

VI. SUPPORTING LETTERS



Caswell F. Holloway
Commissioner

Angela Licata
Deputy Commissioner
Bureau of Environmental
Planning and Analysis
alicata@dep.nyc.gov

59-17 Junction Boulevard
Flushing, NY 11373
T: (718) 565-4366
F: (718) 565-4479

Dr. Ethan Carter
P3 Team Leader
University of Arkansas
College of Engineering
Department of Chemical Engineering
3202 Bell Engineering Center
Fayetteville, Arkansas 72701-1201

Dear Dr. Crater:

The City of New York has been working toward becoming a greener city, with many new initiatives including the decision several years ago for all of our taxis to have hybrid engines by 2012. As part of these efforts, we have been involved for some time now in the search for newer, greener alternatives to the use of fossil fuels in internal combustion engines. We have been looking toward groups like yours on the cutting edge of biofuel research, specifically the manufacture of biofuel from algae, an abundant renewable natural resource in urban areas. We are excited to partner with you as you continue to take steps toward implementation of this promising technology.

The City experiences periodic nuisance macroalgae problems in Jamaica Bay and other areas due to eutrophication. Algal growth also occurs naturally in holding tanks at waste water treatment plants (WWTP's). Currently in the City, no beneficial use is made of either in-situ or WWTP algae, so any practical opportunity to use these potential resources as fuel, while concurrently reducing nutrient levels in our waterways is truly welcome.

We have recently collaborated with the University of Arkansas on a pilot project to convert algae to biofuel at our Rockaway WWTP, and your team has been able to produce butanol from both the WWTP and macroalgae from Jamaica Bay. We are delighted to hear about the automated unit your team is constructing as part of USEPA's "People, Prosperity and Planet" (P3) competition. Our hope is that the current portable unit will be a great stride toward larger units that can produce butanol from algae, and be used as an alternative to gasoline.

Our partnership with the P3 team could include placing a unit that is constructed by your team at the Rockaway WWTP or another location in Jamaica Bay, where it will process algae into butanol. We hope our assistance will help to assess the long-term viability of the project, in addition to identifying potential future applications of your project in NYC. We anticipate that your research can fit into the City's plans to become more environmentally friendly.

We look forward to this partnership with your team as you endeavor to make biofuel from algae a viable option. We believe the City of New York can provide a steady source of raw material to aid in the development of more

renewable fuels, as well as help NYC to become even greener.

If you have any questions, please contact me at 718-595-4458 or jmclaughlin@dep.nyc.gov.



Address: 120 Broadway
New York, NY 10038

Phone: 718-595-4458
Fax: 718-595-4459

Website: www.nyc.gov
Email: info@nyc.gov

NYC Department of
Environmental Protection
120 Broadway
New York, NY 10038
718-595-4458

Sincerely,

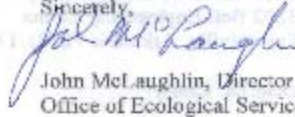
John McLaughlin, Director
Office of Ecological Services

cc: Licata

BUDGET INFORMATION - Non-Construction Programs

SECTION A - BUDGET SUMMARY						
Grant Program Function or Activity (a)	Catalog of Federal Domestic Assistance Number (b)	Estimated Unobligated Funds		New or Revised Budget		
		Federal (c)	Non-Federal (d)	Federal (e)	Non-Federal (f)	Total (g)
1.		\$	\$	\$	\$	\$
2.						
3.						
4.						
5. Totals		\$	\$	\$	\$	\$
SECTION B - BUDGET CATEGORIES						
6. Object Class Categories	GRANT PROGRAM, FUNCTION OR ACTIVITY				Total (5)	
	(1)	(2)	(3)	(4)		
a. Personnel						
b. Fringe Benefits						
c. Travel						
d. Equipment						
e. Supplies						
f. Contractual						
g. Construction						
h. Other						
i. Total Direct Charges (sum of 6a-6h)						
j. Indirect Charges						
k. TOTALS (sum of 6i and 6j)		\$	\$	\$	\$	\$
7. Program Income		\$	\$	\$	\$	\$

BUDGET JUSTIFICATION - University of Arkansas

Salary (\$5,370)

A graduate student will be employed to supervise the team of undergraduate students and instruct them on topics such as control of the process using a logic controller and intricacies of the individual process steps.

Fringe Benefits (\$209)

Graduate student fringe benefits at 3.9% per University policy.

Travel (\$12,000)

Travel funds are budgeted for 2 trips to New York City to supervise implementation of the PEACE-2 equipment at the partner sites and for 2 trips to national conferences to disseminate results of the project.

Equipment (\$21,000)

Funds are budgeted for the construction of the PEACE-2 unit and its components. This will include the reaction vessels and operating equipment to be used on the completed production unit.

Material and Supplies (\$14,000)

Funds will be used for optimization of the process. This will require purchase of various laboratory supplies and chemicals to conduct experiments for hydrolysis, fermentation, and separation components of the process. There will also be peripheral costs associated with the construction of PEACE-2 such as tools and experimentation materials which will not directly fall under the equipment description.

Contractual

None

Other (\$8,077)

The graduate student's tuition for one year is included as a component of the budget (\$7,077).

Shipping of PEACE-1 unit to Jamaica Bay in New York and another location to be determined. (\$1,000).

Facilities and Administrative Costs (\$14,335)

44.0% of MTDC in accordance with F&A Rate Agreement, DHHS, 07/01/09 - 06/30/13.