

1964

Identification of Ninhydrin Positive Components in Ethanolic Extracts of Rice Panicles by Paper Chromatography

C. I. Grable

University of Arkansas, Fayetteville

J. E. Presley

University of Arkansas, Fayetteville

George E. Templeton

University of Arkansas, Fayetteville

Follow this and additional works at: <https://scholarworks.uark.edu/jaas>



Part of the [Plant Biology Commons](#), and the [Plant Pathology Commons](#)

Recommended Citation

Grable, C. I.; Presley, J. E.; and Templeton, George E. (1964) "Identification of Ninhydrin Positive Components in Ethanolic Extracts of Rice Panicles by Paper Chromatography," *Journal of the Arkansas Academy of Science*: Vol. 18 , Article 8.

Available at: <https://scholarworks.uark.edu/jaas/vol18/iss1/8>

This article is available for use under the Creative Commons license: Attribution-NoDerivatives 4.0 International (CC BY-ND 4.0). Users are able to read, download, copy, print, distribute, search, link to the full texts of these articles, or use them for any other lawful purpose, without asking prior permission from the publisher or the author.

This Article is brought to you for free and open access by ScholarWorks@UARK. It has been accepted for inclusion in *Journal of the Arkansas Academy of Science* by an authorized editor of ScholarWorks@UARK. For more information, please contact scholar@uark.edu.

IDENTIFICATION OF NINHYDRIN POSITIVE COMPONENTS IN ETHANOLIC EXTRACTS OF RICE PANICLES BY PAPER CHROMATOGRAPHY

C. I. Grable¹, J. E. Presley², and G. E. Templeton
University of Arkansas

The readily extractable amino acids and amides in rice panicle tissue are being studied to determine their role in the mechanism of physiologic resistance to the kernel smut pathogen, *Tilletia barclayana* (Bref.) Sacc. and Syd. Paper chromatography, because it is rapid and reliable, is ideally suited for examining amino acid pools from tissue whose resistance has been modified by manipulation of the environment or for following changes in pool composition during growth, either preceding, during, or after infection by this localized parasite in a resistant or susceptible host.

Since the origin of modern paper chromatography by Consden, Gordon and Martin (2), multitudinous modifications for separation and identification of amino acids have been reported (1, 4, 5, 7, 8, 10). This report gives the method selected from these many modifications which has been found to be best suited in our laboratory for extraction, desalting, separation and identification of the 80 percent ethanol soluble, ninhydrin positive components of rice panicles at anthesis by two dimensional descending paper chromatography.

MATERIALS AND METHODS

1. Extraction.

The Bluebonnet 50 rice panicles at anthesis were dried to constant weight at 70° C, ground to pass a 40 mesh sieve in a Wiley Mill, and extracted with 80 percent ethanol in an Omnimixer at 8000 R.P.M.. A three gram sample of dried tissue was blended three times for 15 minutes each in 50, 40 and 30 ml portions of ethanol in a stainless steel cup (nominal volume 50 ml) at room temperature. The supernatant from each extraction was decanted and filtered through Whatman No. 1 filter paper and the filtrates were combined.

2. Desalting.

The combined filtrates were desalted with a cation exchange resin according to the procedure of Plaisted (6) in which 100 ml of filtrate was passed through a .9 x 3-5 cm column

¹Research Assistant, Department of Plant Pathology.

²Participant-Undergraduate Research Participation Program in Plant Pathology-NSF 21692.

of acidic Dowex 50 W x 8 (100-200) bedded in 80 percent ethanol at a flow rate of 3 ml/min. After elution of the amino acids from the column with ammonium hydroxide, the eluates were taken to dryness in a Rinco rotary evaporator. The residue was taken up in 10 percent isopropanol, made up to 10 ml in a glass stoppered volumetric flask, then stored at room temperature until used for spotting papers for chromatography.

3. Chromatography.

The amino acid solutions were spotted on $18\frac{1}{4}$ x $22\frac{1}{2}$ inch sheets of Whatman No. 1 filter paper and were separated by two dimensional descending chromatography. The solvent systems used were phenol: water (4:1) or methanol: ethanol: water: urea (45:45:10:0.5) v:v:v:w in the first direction ($22\frac{1}{2}$ inch length in the machine direction) and n-butanol: acetic acid: water (4:1:6) (upper layer) in the second direction. A spot, .5 to 1 cm in diameter, containing 100-200 lambda of the amino acid mixture was applied to each paper at the appropriate corner, 3 inches from either edge of the paper with 5 or 10 lambda, self-filling micropipettes. A hair dryer was used intermittently to hasten drying, plastic gloves were used to avoid contamination of the papers with perspiration and a glass plate which supported the papers during spotting was cleaned with acetone after spotting each paper. The pipettes were cleaned in detergent solution, rinsed five times in de-ionized water and dried with acetone.

The spotted papers were folded and developed in an insulated Chromatocab in a descending manner. (Fig. 1). Five to 10 papers were developed at a time with 75 or 100 ml of the solvent per trough for one or two papers respectively. The temperature ranged from 23 to 28° C during the course of this work with temperature variation during one development not exceeding 1° C. Time for development ranged from 15 to 21 hours depending upon solvent, number of papers, temperature, length of paper, etc. Development was begun without an equilibration period and solvents were permitted to travel to within $\frac{1}{2}$ inch of the bottom of the paper before being removed and dried. The folded edge was removed at the antisiphon rod line and the paper was similarly refolded along the edge perpendicular to the machine direction prior to development in the second solvent.

The papers were dried in a forced air oven at 30° C. Papers developed in phenol were dried for 8 hours before developing in the second solvent whereas papers developed in the other two solvents were dried for 2 hours. After completion of drying after the second development, the papers were sprayed or dipped in ninhydrin and heated for color development.

Ninhydrin Positive Components in Rice Panicles

Figure 1. Method of marking and folding paper for two-dimensional descending paper chromatography.

The phenol solvent was prepared immediately before use by shaking together 4 parts liquified phenol (Merck 88%) and 1 part de-ionized water in a separatory funnel until complete solution was affected. One liter of this solvent was used repeatedly in the bottom of the chamber together with a small container of .5 g sodium cyanide in 15 ml water to reduce breakdown of phenol during development in this solvent.

Separate Chromatocabs were used for each solvent system when practical, or cabinets were thoroughly cleaned with detergent and air dried between different solvent developments.

The methanol:ethanol:water:urea solvent was prepared by mixing 45 parts absolute methanol, 45 parts absolute ethanol, 10 parts de-ionized water and 0.5 grams urea.

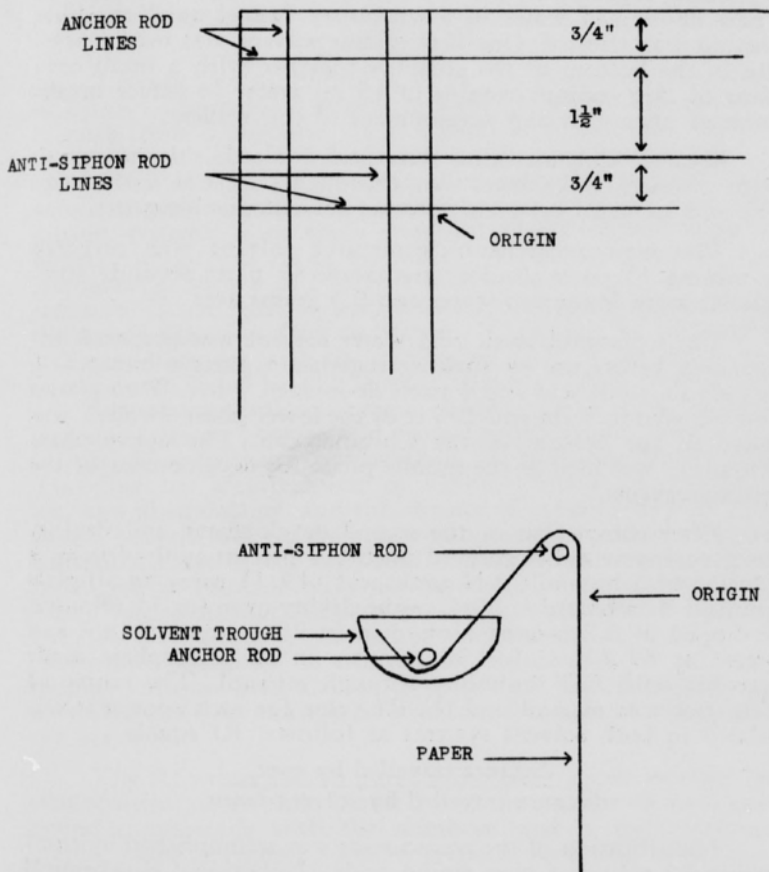
The n-butanol:acetic acid:water solvent was prepared immediately before use by shaking together 4 parts n-butanol, 1 part glacial acetic acid and 6 parts de-ionized water. Two phases were allowed to form and 100 cc of the lower phase (water) was placed in the bottom of the Chromatocab. The upper phase (butanol) was used as the mobile phase for development of the chromatograms.

After completion of the second development and drying, the papers were either sprayed with 0.2 percent ninhydrin in a solution of n-butanol: 2 N acetic acid (19:1) using an all glass atomizer then heated at 80°C in the drying oven for 15 minutes, or dipped in 0.2 percent ninhydrin in 95 percent ethanol and heated at 65-70° C for 30 minutes in an atmosphere made anerobic with CO² bubbling through ethanol. The center of each spot was marked and the R_f value for each spot was calculated in both solvent systems as follows: R_f equals

$$\frac{\text{distance travelled by spot}}{\text{distance travelled by solvent front.}}$$

Identification of the amino acids was accomplished by comparing R_f values of pure amino acids (Nutritional Biochemical Co., Cleveland, Ohio) in the same solvent systems and by co-chromatography i. e. adding known amino acid solutions to the spot containing solutions from tissue extracts and chromatographing. In some cases color differences aided in identification.

The chromatograms were preserved by fixing the developed color with copper and coating the paper with plastic. The papers were freed of traces of solvent by washing in equal parts of petroleum ether: acetone (v:v) before treating with ninhydrin. After the ninhydrin treatment and color development the dried chromatogram was dipped in dilute copper nitrate (1 ml of saturated aqueous Cu (NO³)² plus 0.2 ml of 10% v/v HNO³ diluted to 100 ml with ethanol) and exposed momentarily to

Ninhydrin Positive Components in Rice Panicles

ammonia vapor. The paper was then dried at room temperature and sprayed with Krylon crystal clear spray coating No. 1303

RESULTS

Twenty two ninhydrin positive components were separated by two-dimensional paper chromatography of the ethanolic extracts from Bluebonnet 50 rice panicles at anthesis. Eighteen of these were identified by color, co-chromatography and by comparison of their Rf values in three solvent systems with Rf values of pure amino acids chromatographed in the same three solvent systems. Four spots were not identified and were designated unknowns A, B, C, and D. A two-dimensional chromatogram is shown in Figure 2 with phenol:water in the first direction (from right to left) and butanol:acetic acid:water in the second direction (top to bottom). The number or letter of each spot coincides with the number or letter of the amino acid or unknown listed on the chromatogram. This solvent system does not separate isoleucine from leucine, valine from methionine, alpha amino butyric acid from gamma amino butyric acid and the phenylalanine spot overlaps the isoleucine-leucine spot. Therefore the identification of valine, gamma amino butyric acid and phenylalanine, and the absence of methionine and alpha amino butyric acid on this chromatogram is based on the separation of these in the methanol: ethanol: water:urea solvent. Isoleucine and leucine were not separated in any solvent used. The assumption that both are present is based on the fact that both are ubiquitous in biological material. In addition to the compounds identified in extracts of Bluebonnet 50 rice, methionine sulfone, beta alanine, tryptophane and histidine were identified and two unknowns were found in extracts from other rice varieties.

The Rf values for 40 pure amino compounds in three solvent systems are given in Table I and the number of each compound corresponds with the numbers used in the chromatographic maps in Figures 3 and 4, prepared from this data.

DISCUSSION AND SUMMARY

The degree of separation and identification of the amino acids is deemed adequate for the physiological studies envisioned. The majority of the ninhydrin-positive spots were chromatographically identified and those which were not, were in relatively low concentration. These unknowns might be amino acids previously described (3) but not yet readily available from normal commercial sources, undescribed amino compounds, or small peptides. Unless these unknowns are found to be closely related to some disease reaction of rice it would not seem warranted to go through the laborious procedures necessary for unequivocal identification of these compounds. (11)

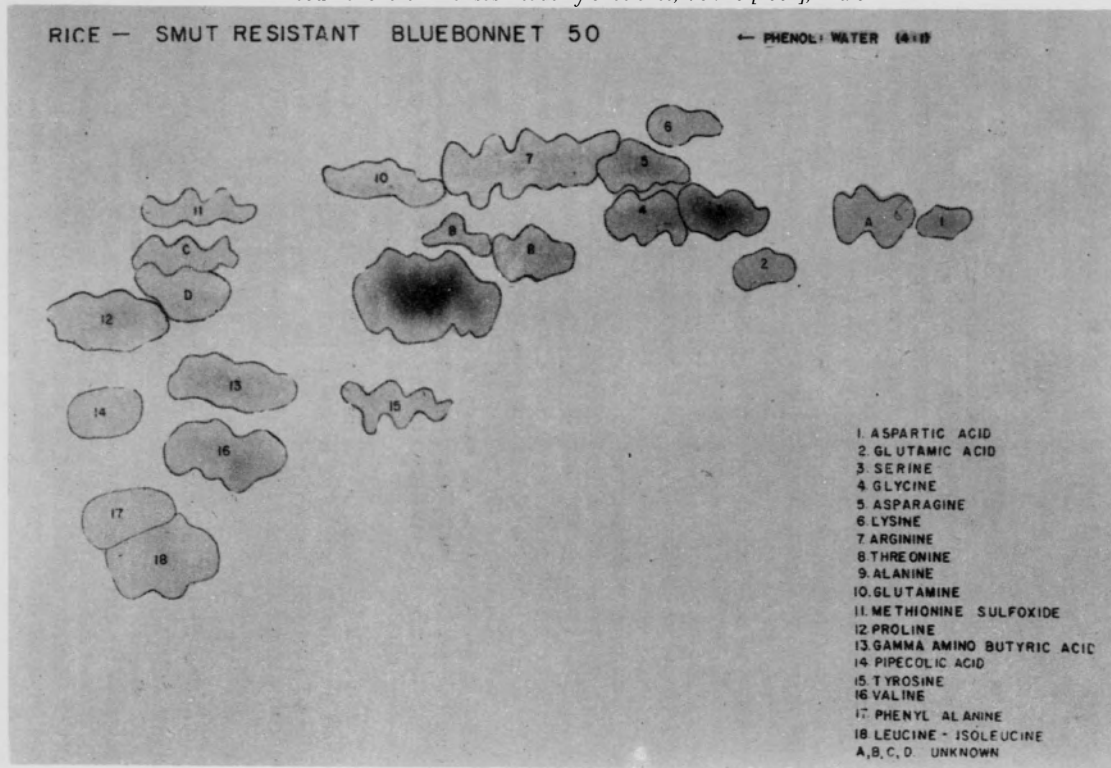

The absence of some of the common protein amino acids such as cystine, cysteine, methionine, tryptophane is not interpreted as an absence of these amino acids in rice tissue but a lack of their occurrence in detectable quantities using these procedures. In fact, the presence of methionine is strongly suggested since no precautions were taken to prevent its oxidation in these procedures. Likewise no precautions were taken to avoid breakdown of glutamine or asparagine to their respective acids.

LITERATURE CITED

1. BLOCK, R. J., E. L. DURRUM, and G. ZWEIG. 1958. A manual of paper chromatography and paper electrophoresis. Second Edition. Academic Press. New York 710 pp.
2. CONSDEN, R., A. H. GORDON, and A. J. P. MARTIN. 1944. Qualitative analysis of proteins, a partition chromatographic method using paper. *Biochemical Journal*. 38: 224-232.
3. GREENSTEIN, J. P. and M. WINITZ. 1961. Chemistry of the amino acids. Vol. 1. John Wiley and Sons, Inc. N. Y. pp. 25-36.
4. HEFTMAN, ERICH. 1961. Chromatography. Reinhold Publishing Corporation. New York.
5. LAWRENCE, J. M., T. U. MILLER, and L. W. RASMUSSEN. 1960. Estimation of amino acids in plant tissue by paper chromatography. Technical Bulletin 32, Washington Agriculture Experiment Stations.
6. PLAISTED, P. H. 1958. Clearing free amino acid solutions of plant extracts for paper chromatography. *Contributions from Boyce Thompson Institute* 19 (3): 231-244.
7. SMITH, IVOR. 1960. Chromatographic and electrophoretic techniques. Volume 1, Second Edition. Interscience Publishers, Inc. N. Y. 617 pp.
8. THOMPSON, J. P., S. I. HONDA, G. E. HUNT, R. M. KRUPKA, C. J. MORRIS, L. E. POWELL, Jr., O. O. SILBERSTEIN, G. H. N. TOWERS, AND R. M. ZACHARIUS. 1959. Partition chromatography and its use in the plant sciences. *The Botanical Review* 25: 1-263.
9. THOMPSON, J. F., C. J. MORRIS and ROSE K. GERLING. 1959. Purification of plant amino acids for paper chromatography. *Anal. Chem.* 31: 1028-1030.
10. THOMPSON, J. F. and C. J. MORRIS. 1959. Determination of amino acids from plants by paper chromatography. *Anal. Chem.* 31: 1031-1037.
11. Winitz, M. 1962. Identification of the elusive amino acid. In *Amino Acid Pools*. J. T. Holden Ed. Elsevier Publishing Co. N. Y. pp. 5-23.

Arkansas Academy of Science Proceedings

TABLE I

Rf. values of pure amino acids in three solvent systems

Spot Number	Amino acid	Rf values in		
		Phenol ¹	n-butanol ²	Methanol ³
1	Cysteic acid	.11	.07	.17
2*	Aspartic acid	.19	.17	.18
3	Cysteine	.25	.05	.07
4	Cystine	.25	.06	.10
5	Ornithine	.29	.09	.10
6	Djenkolic acid	.32	.08	.05
7*	Glutamic acid	.30	.23	.24
8*	Lysine	.38	.12	.12
9*	Serine	.37	.18	.31
10	Dihydroxyphenylalanine	.35	.27	.32
11*	Asparagine	.40	.13	.15
12*	Glycine	.40	.18	.29
13	Homocystine	.40	.15	.10
14	Homocysteine	.40	.17	.13
15*	Arginine	.44	.14	.13
16*	Threonine	.49	.23	.41
17*	Histidine	.51	.12	.20
18*	Glutamine	.57	.16	.23
19*	Alanine	.57	.28	.54
20	Ethanolamine	.55	.31	.76
21*	Beta alanine	.61	.30	.40
22*	Tyrosine	.65	.43	.48
23	Citrulline	.61	.18	.26
24*	Methionine sulfone	.60	.22	.34
25	Hydroxyproline	.64	.20	.36
26*	Methionine sulfoxide	.76	.18	.34
27	Sarcosine	.76	.24	.50
28	Alpha amino butyric acid	.75	.37	.63
29*	Gamma amino butyric acid	.75	.38	.50
30*	Valine	.77	.48	.68
31	Methionine	.77	.48	.61
32*	Tryptophane	.77	.55	.37
33*	Phenylalanine	.82	.62	.65
34*	Leucine	.79	.64	.76
35*	Isoleucine	.79	.64	.76
36	Diiodotyrosine	.79	.75	.54
37-A	Ethionine	.80	.31	.71
37-B	Ethionine	—	.62	.71
38*	Proline	.83	.31	.56
39*	Pipecolic acid	.89	.41	.71
40	Beta amino butyric acid	.95	.28	.79
A*	Unknown	.25	.16	
B*	Unknown	.58	.18	
C*	Unknown	.39	.20	
D*	Unknown	.39	.24	
E*	Unknown	.29	.13	
F*	Unknown	.32	.09	

(Table 1 continued)

- 1—phenol : H₂O (4:1)
 - 2—n-butanol : acetic acid : H₂O (4:1:6)
 - 3—Methanol : ethanol : H₂O : Urea (45 : 45 : 10 : 0.5)
- *present in rice panicles

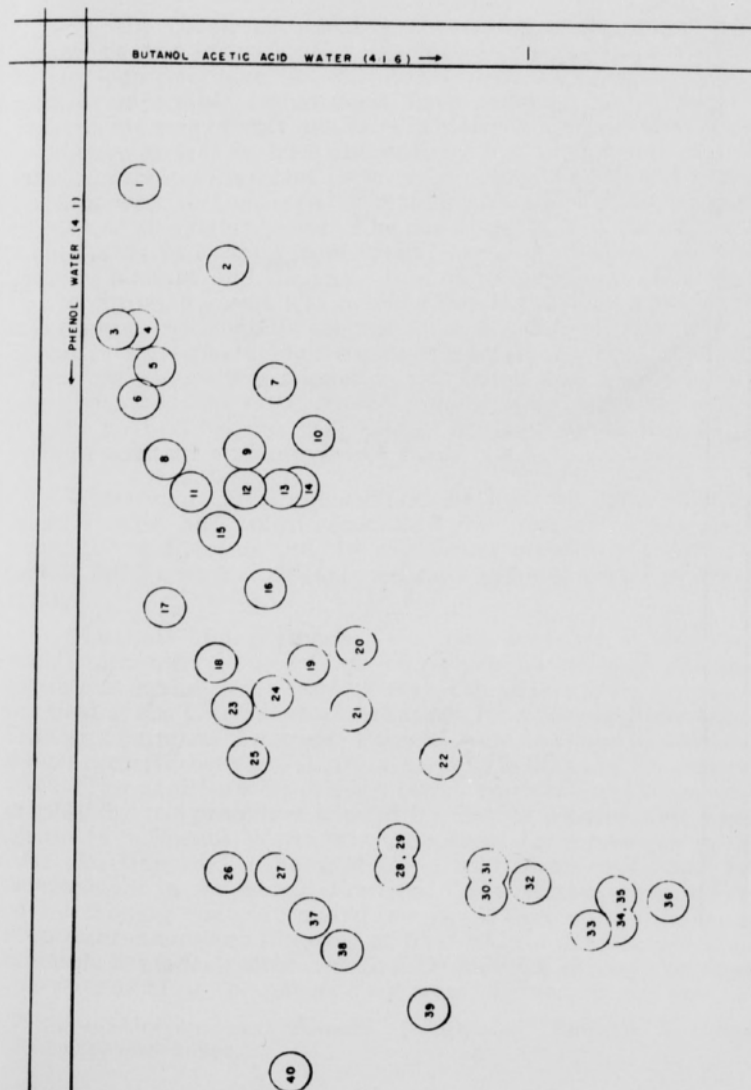

← METHANOL ETHANOL WATER UREA (45.45.10.0.5)

BUTANOL ACETIC ACID WATER (4:1:6) →

